

SUMITOMO

SH250-6

- Engine Rated Power (Net): 132.1 kW·179.6 PS
- Operating Weight:
 - SH250-6 24,800~25,400 kg
- Bucket: ISO/SAE/PCSA Heaped: 0.8~1.3 M3



SUMITOMO



**SUMITOMO (S.H.I.)
CONSTRUCTION MACHINERY CO., LTD.**

731-1 Naganumahara-cho, Inage-ku, Chiba, 263-0001 Japan
For further information please contact: Phone : +81-43-420-1829 Facsimile : +81-43-420-1907

We are constantly improving our products and therefore reserve the right to change designs and specifications without notice.
Illustrations may include optional equipment and accessories and may not include all standard equipment.

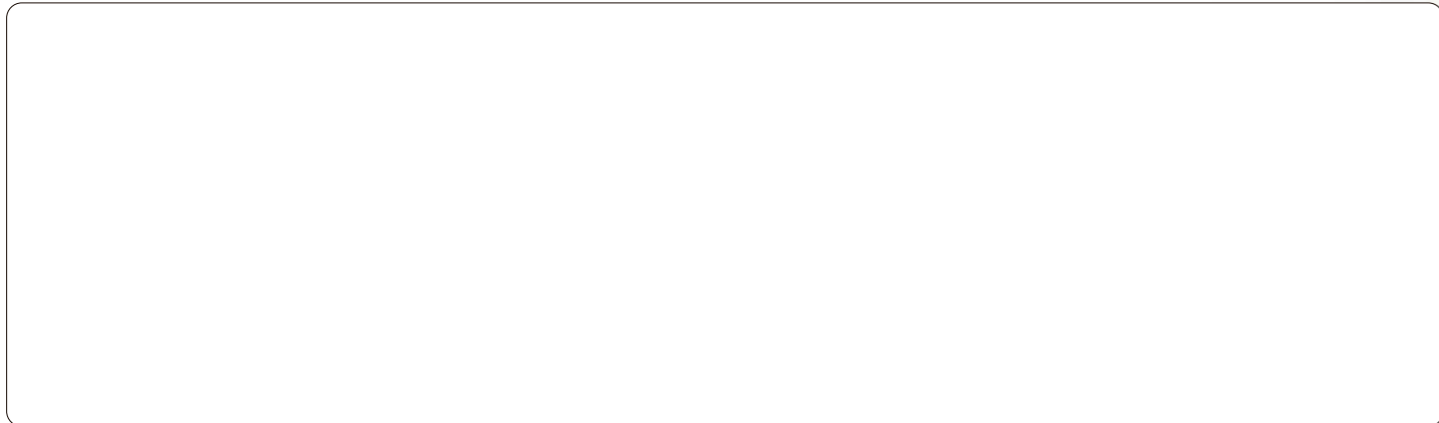

Performance Refined. Evolution Defined.



Engine and Hydraulics 04-07

- New Generation Engine System "SPACE 5+"
- New Hydraulic System "SIH:S+"
- SUMITOMO Fuel Efficiency Technology
- Drastically Increased Productivity

Durability and Maintenance 08-11

- High Rigidity Attachments
- EMS
- Ground Level Maintenance

Safety and Operator Comfort 12-17

- Stylish and Spacious Cabin
- High-Definition Full Colour LCD Monitor

Specifications 18-27

ENGINEERED IN JAPAN

The world knows that Japanese designed and engineered products represent the highest quality, especially for Industrial Products. The hydraulic excavator is no exception when a totally integrated concept is required in design work involving key components, manufacturing engineering, and product quality assurance in the factory. SUMITOMO hydraulic excavators are designed and manufactured today to meet the global demands of our many customers with the concept of Performance, Reliability, and Fuel Efficiency foremost in our minds. This proven Japanese technology and quality gives SUMITOMO excavator customers total peace of mind and provide a complete solution for the demands of the construction industry.



**Performance Refined.
Evolution Defined.**



New Engine System **SPACE 5+ PLUS** + New Hydraulic System **SIHIS PLUS** = **12% Reduction in Fuel Consumption**
(as compared with SH240-5 [H mode])

New Generation Engine System "SPACE 5+"

The new engine system optimises fuel efficiency and environmental performance via the advanced common rail fuel injection system, cooled EGR system, and turbocharger. At the same time, excellent response times are achieved.

Engine and Hydraulics



SH250-6 has achieved a 12% fuel saving in comparison with our DASH 5 series, by fusing the new generation engine system "SPACE 5+" and the new hydraulic system "SIH:S+", further refining fuel efficiency. At the same time the newly developed ISUZU engine, contributes greatly to the environment.

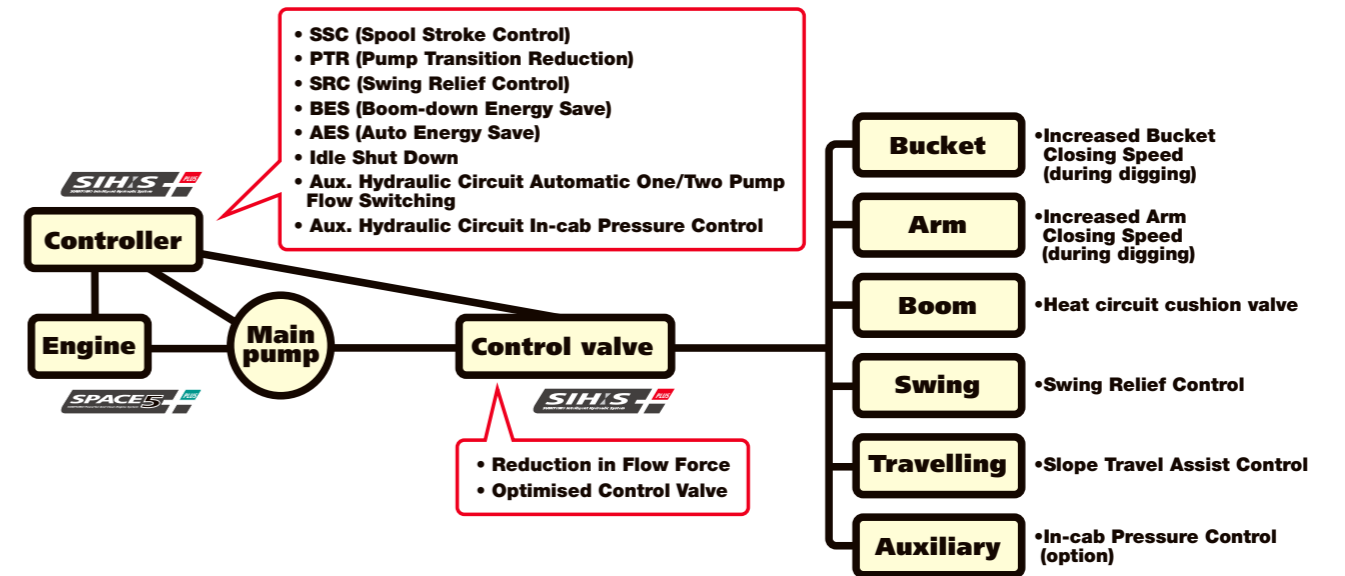

Mode Selection by Throttle **SUMITOMO UNIQUE DESIGN**

There are three working modes available: SP (Super Power) for heavy duty applications, H (Heavy) for normal working conditions, A (Auto) for a wide range of operations.



Further Improvement of Fuel Consumption

The new technology has improved operations and reduced fuel consumption on each working mode.

- SP mode **3% reduction in fuel consumption**
- H mode **12% reduction in fuel consumption**
- A mode **12% reduction in fuel consumption**
(as compared with SH240-5)

*Fuel consumption may vary from time to time depending on site and working conditions, operator skill and other circumstances.

ECO Gauge Showing Low Energy Operation

The energy saving conditions can be seen at a glance, as well as the fuel consumption indicator shown on the monitor.



SUMITOMO Technology for Fuel Efficiency

- **SSC (Spool Stroke Control)** **SUMITOMO UNIQUE DESIGN**
Reduces engine load upon heavy duty operation.
- **BES (Boom-down Energy Save)** **SUMITOMO UNIQUE DESIGN**
Lowers engine speed upon boom-down and swing operation which does not require large oil flow.
- **AES (Auto Energy Save)** **SUMITOMO UNIQUE DESIGN**
Lowers engine speed accordingly when low engine load is sensed.
- **PTR (Pump Transition Reduction)**
Decreases engine load when the pump flow requirement is reduced upon abrupt pump load.
- **Idle Shut Down & Auto Idle**

Upon activation, idle shut down automatically shuts the engine down when the machine is not in operation for set amount of time. Auto Idle is also available, which makes the engine begin idling approximately five seconds after the operation levers are in neutral position.



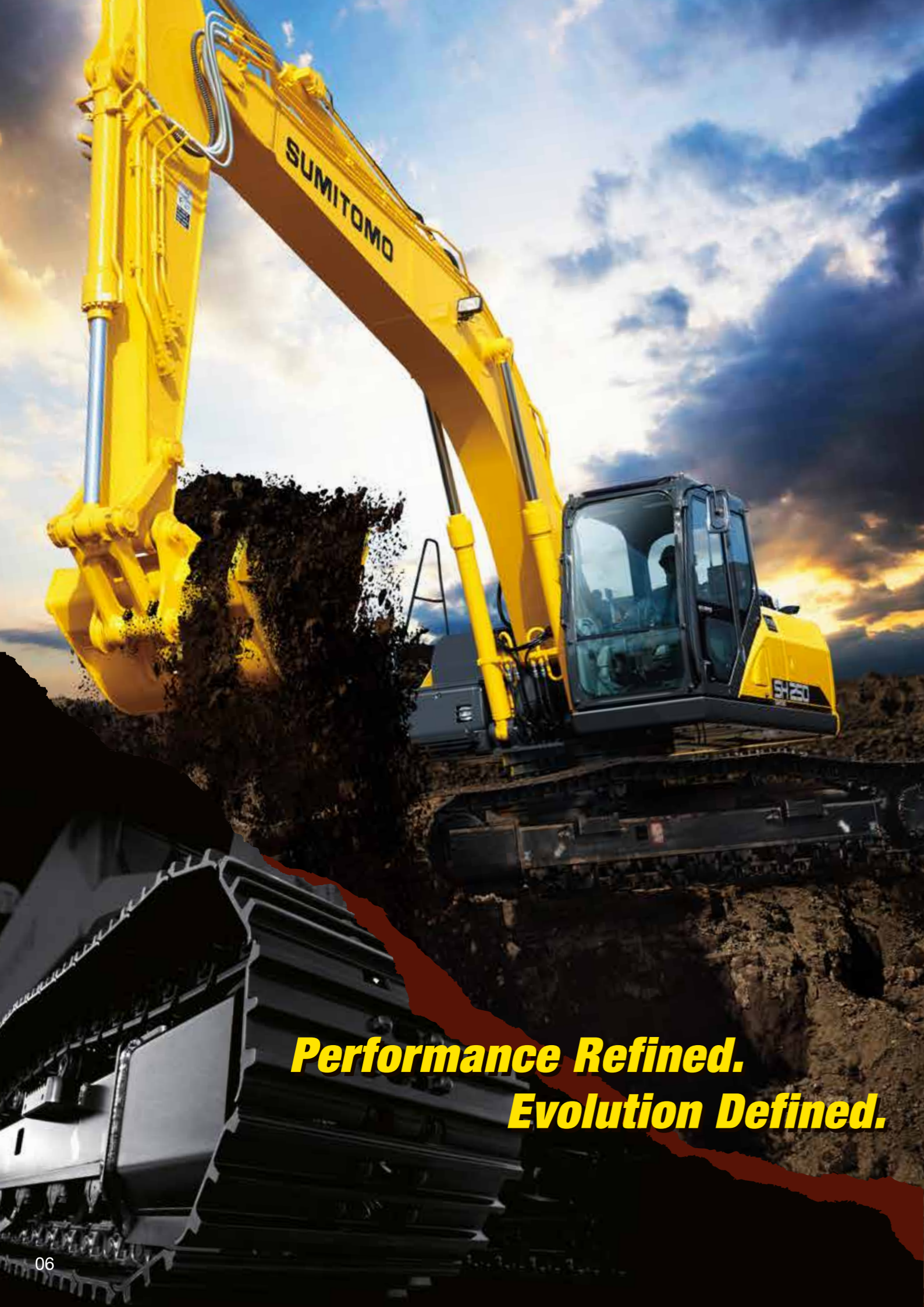

**Performance Refined.
Evolution Defined.**

Engine and Hydraulics



SUMITOMO's original technology Spool Stroke Control (SSC), perfectly matches the engine and hydraulic power, and further improves the operational speed whilst maintaining smooth control of the machine.

Work Efficiency Drastically Increased

Spool Stroke Control (SSC) variably controls spool port flow rate, depending on the condition of operation. Improved power, speed, and smoother controls mean that work efficiency is dramatically increased.

4% Faster Cycle Time (SP mode)

Speed increase by 4% in cycle time has been achieved, giving further advance in productivity (as compared with SH240-5 [SP mode]).

Real Digging Power

The true digging force can not be expressed by a maximum digging power figure listed in sales brochures. With an improved hydraulic system and with a large arm cylinder, the arm-in motion speed slowdown is minimised. The digging power when combined with the attachment speed in motion convert to the operator's "Real Digging Power".

Automatic Power Boost

The digging power increases automatically in quick response to the working conditions during heavy-duty digging work. This is a design unique to SUMITOMO, and continues for eight seconds (SP/H mode).

Remarkable Combined Operation

Prevents rapid deceleration upon combined operation such as boom/arm operation with travel, ensuring stable performance.

Auxiliary Hydraulic Circuit

Selection of auxiliary circuit has been made easier. Correct pump flow (one pump or two pump) will automatically be activated upon operator's selection of the circuit. In-cab pressure control (option) also available.

Speed and Power, Increases Productivity • SP mode **4%** faster cycle time (as compared with SH240-5)

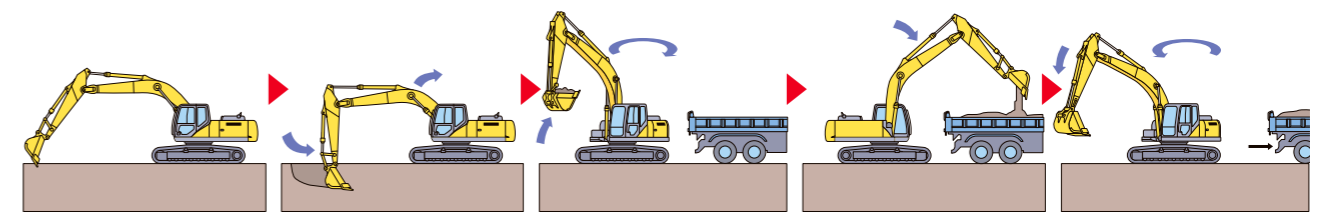

*Based on SUMITOMO's testing condition and results.

Operating Condition Easily Viewable on Display

Various control such as working modes and auxiliary hydraulic setting can be easily selected by the universally designed switch panel, and what's being selected can be easily viewed on the 7" wide monitor.





Durability and Maintenance

High Rigidity Attachments

The structure of the boom and arm is designed for strength and durability. In addition, high strength castings are used for the boom base and arm end for reliability.

• Boom

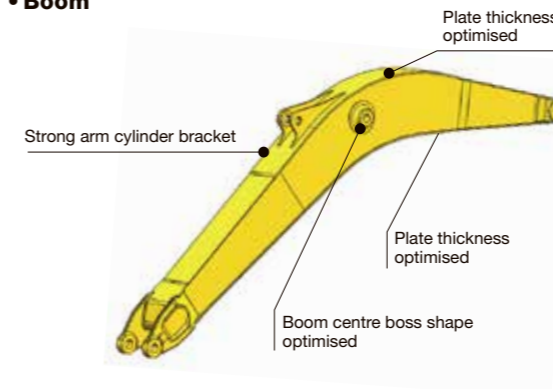

• Arm

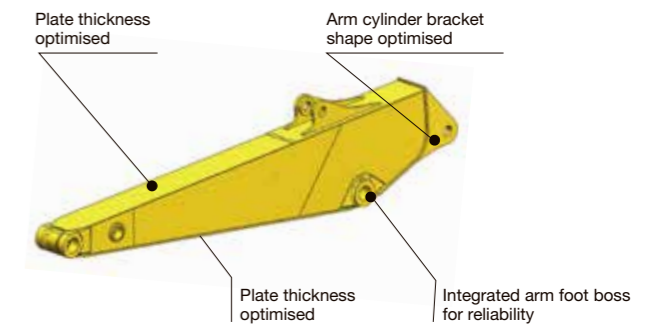

EMS (Easy Maintenance System) as Standard

SUMITOMO's EMS keeps the pins and bushes fully lubricated at all times and prevents rattling. This system significantly extends the service life of the pins and bushes.

The lubrication interval around the bucket is 250 hours, and for the other sections is 1,000 hours, keeping the joints lubricated for a long time and extending the service life of parts by reducing abrasion and rattling.

• **Bucket greasing interval: 250 hours**

• **Greasing interval for other sections: 1,000 hours**

* The greasing interval depends on the working conditions.

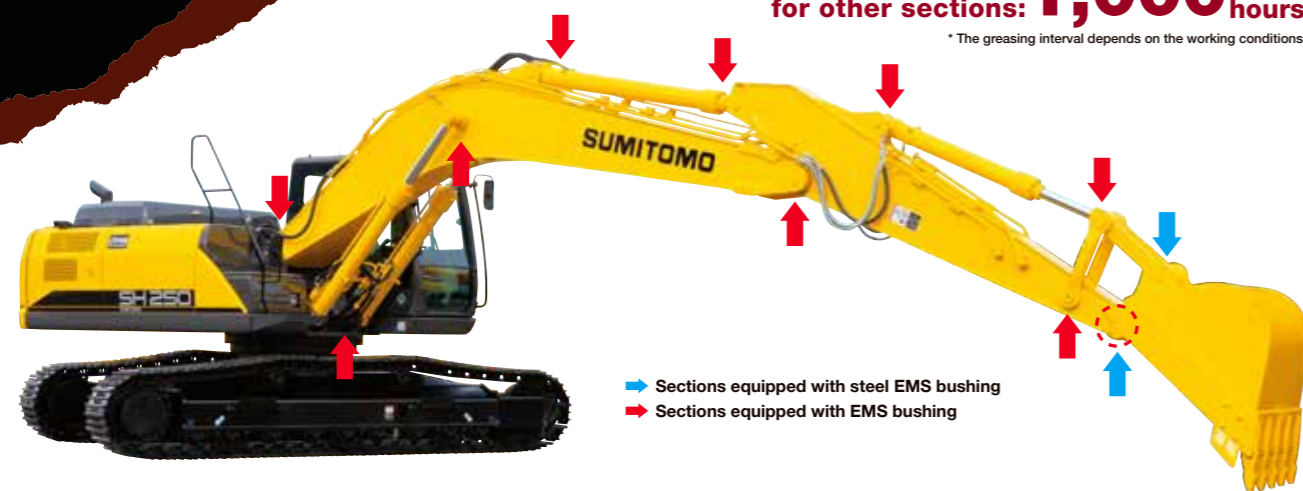

➡ Sections equipped with steel EMS bushing
➡ Sections equipped with EMS bushing

■ EMS bushing

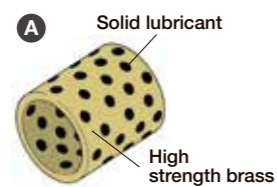

A A solid lubricant embedded in high strength brass forms a layer on the bushing surface to prevent contact between metals, maintaining an excellent lubricated state to reduce abrasion of joints.

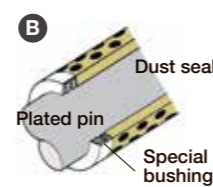

B The surface of the pin is plated to increase the surface hardness and improve the wear resistance accordingly.

■ Steel EMS bushing



Steel EMS is installed around the bucket

Precautionary use of EMS

- ① Grease is enclosed, however greasing is necessary every 1000 hours or six months depending on the level of dusting conditions.
- ② Greasing is also necessary after any components have been submerged underwater for prolonged periods.
- ③ Greasing is also recommended after use with hydraulic breakers, crushers or other high impact attachments such as Rock Saws etc.
- ④ Bucket pins should be cleaned thoroughly when removing or attaching new buckets.

Bucket

A one-piece wear plate covers the weld section for long increase the wear life of the bucket.

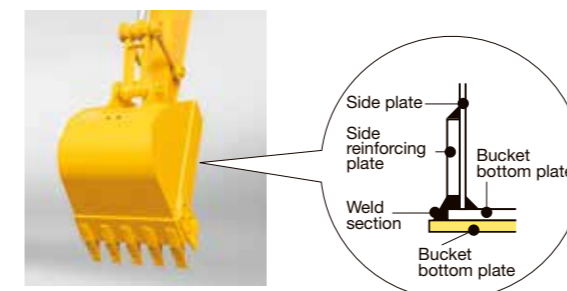

High Rigidity Swing Frame

The swing frame has been strengthened to support the new ROPS cabin, as well as to increase durability.

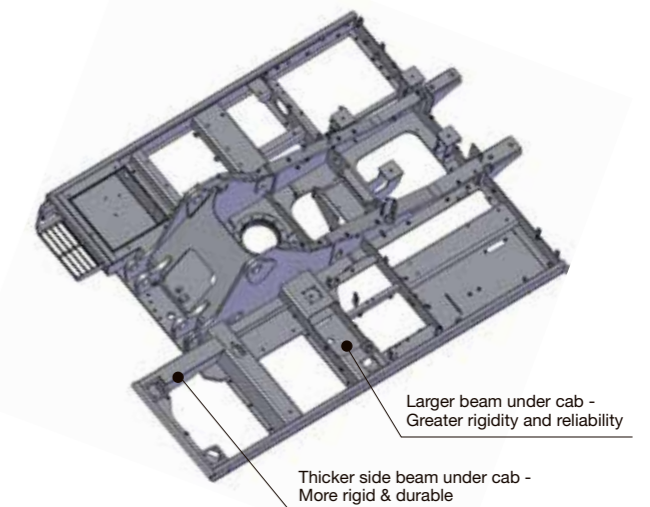

High Rigidity Undercarriage

For improved mobility, the track system has been strengthened ensuring longer wear life, performance, and improved reliability.

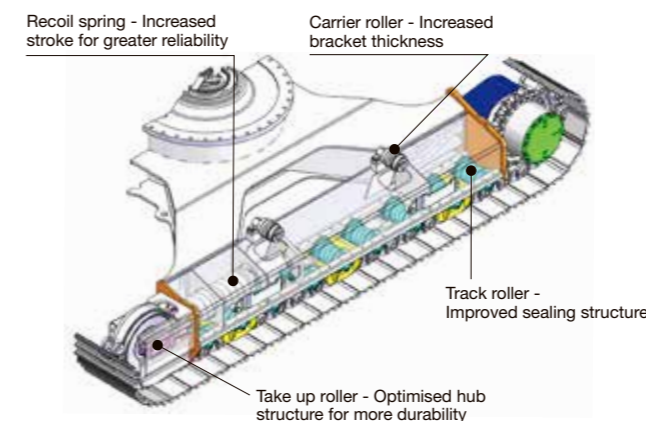



**Performance Refined.
Evolution Defined.**

Durability and Maintenance

Serviceability and durability are also important points of machine performance. Ground level access to the engine area makes daily maintenance extremely straightforward. Reliability has been further enhanced by increasing cooling capability and durability.

Ground Level Access to Engine Area Improves Preventative Maintenance

Parts cleaning and maintenance are possible from the ground without climbing onto the upper structure of the excavator body.

• Increased Cooling Capability

With the larger radiator and oil cooler, cooling capacity is increased, thus improving reliability. In addition, cleaning of the dust-proof net is simplified.

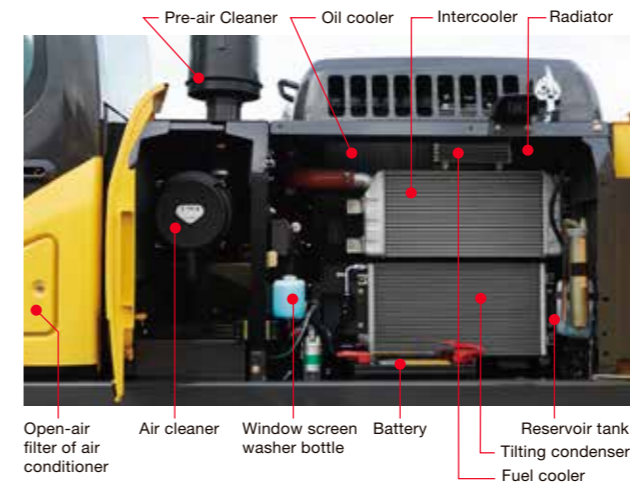

• Easy Filter Replacement

A fuel prefilter with water separator and water level sensor are provided as standard equipment to reduce maintenance trouble. In addition, the fuel and oil filters are installed at ground-accessible location to facilitate replacement.

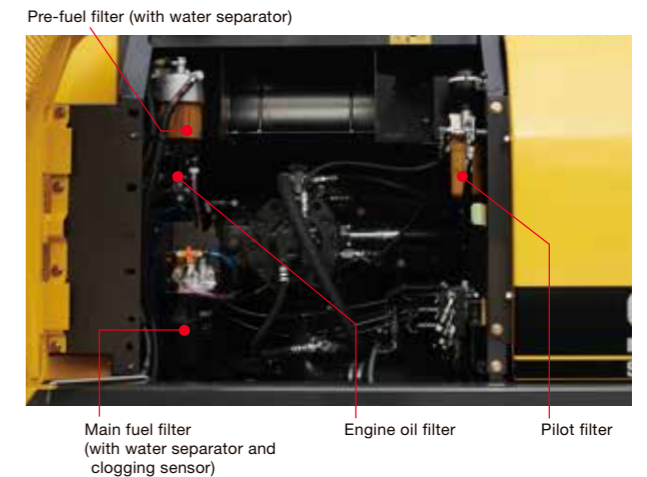

High-Performance Return Filter

The hydraulic oil change interval is 5,000 hours, and the return filter change interval is 2,000 hours. One high performance return filter keeps the same level of filtering as a nephron.



• Hydraulic oil change: **5,000** hours

• Life of filter: **2,000** hours

* The oil and filter change interval varies by the working conditions.

Pre-air Cleaner (option)

An automatic exhaust type pre air cleaner option is available. The air cleaner cleaning frequency is minimised, even when operating in dusty conditions.



Easy Access to A/C Filter

The air intake filter is located in a lockable compartment to make it easier to replace, and access to the inside cab filter has been simplified.



Cab Floor Mat **SUMITOMO** UNIQUE DESIGN

The washable floor mat has been redesigned for ease of removing and cleaning.



Fuse Box Location

The fuse box has been located in a separate compartment behind the seat, allowing easier access.



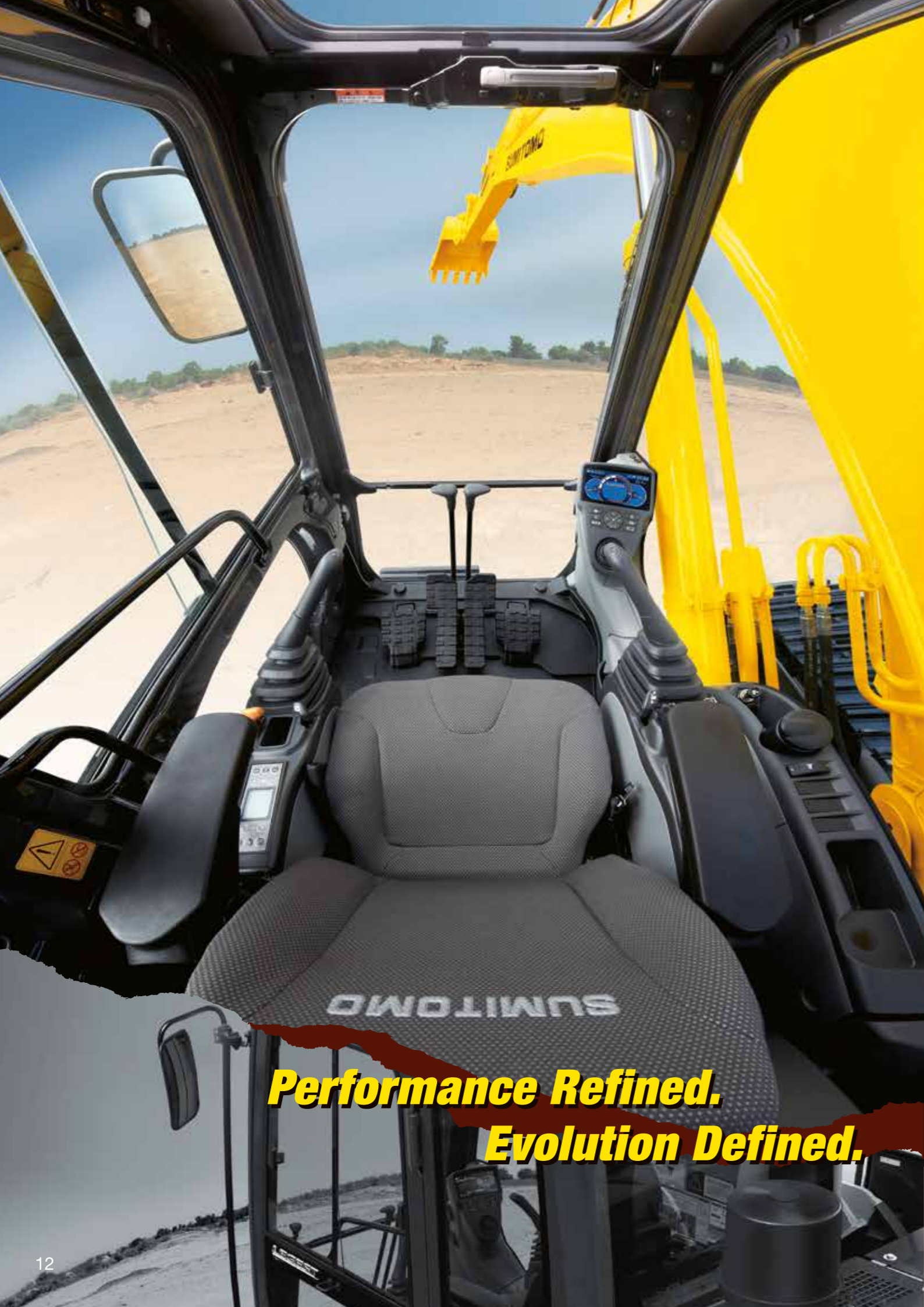

**Performance Refined.
Evolution Defined.**

Safety and Operator Comfort

Planning for safety in the event of a roll accident, a new strengthened safety cabin has been provided. The reinforced cabin greatly increases the operator's safety.

Newly Designed Strengthened Safety Cabin

The optimised design and strengthened parts increase the overall cabin strength. Even if the shovel were to tip over, the safety of the operator is ensured by keeping cabin deformation to a minimum.

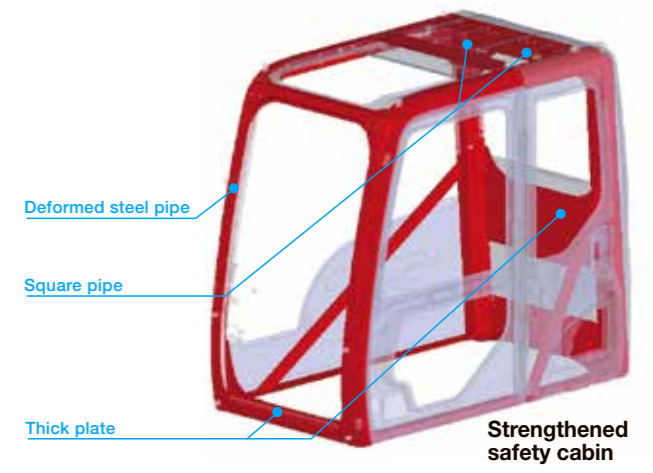

Wide View Increases Safety of Work

In addition to the wide front view, the upper view has been widened to enhance work safety.



Safe and Easy Entry into and Exit from the Cab

A large handrail for easy opening/closing of the door and increased floor space permit the operator to get in and out of the cab easily.



New Cab Suspension Mounts

The new cab suspension mounts reduce vibration and impact transmitted to the cabin, and improve the operator's sitting quality and reduce operator fatigue. The sealed and pressurised cabin prevents entry of dust from outside.

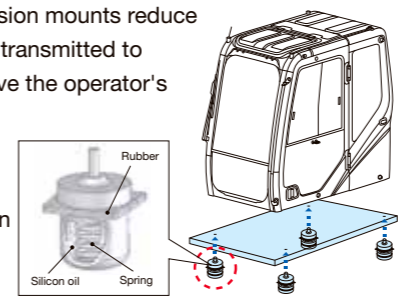

New OPG Level 2 Head Guard (option)

OPG Level 2 head guard is available as an option. The see-through grille has been redesigned for better protection and visibility.



Easy Access to the Upper Structure

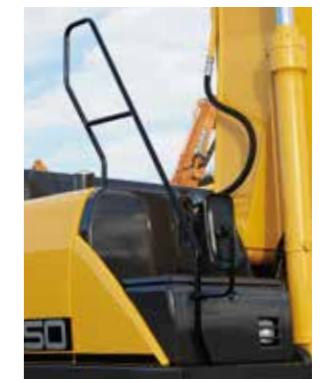

Cab Front Guard (option)

Optional cab front guard improves operator's safety from job site hazards.



**Performance Refined.
Evolution Defined.**

Safety and Operator Comfort

The spacious cab on suspension mounts and reclining suspension seat softens operator fatigue and provide a relaxed environment.

Stylish and Spacious Cab

Wide cab space and floor space ensure more comfortable operation. In addition to the tilting console that is adjustable in four steps vertically, the increased sliding distance ensures optimum working conditions. Moreover, in cab noise level has been reduced by 2 dB (as compared with SH240-5).

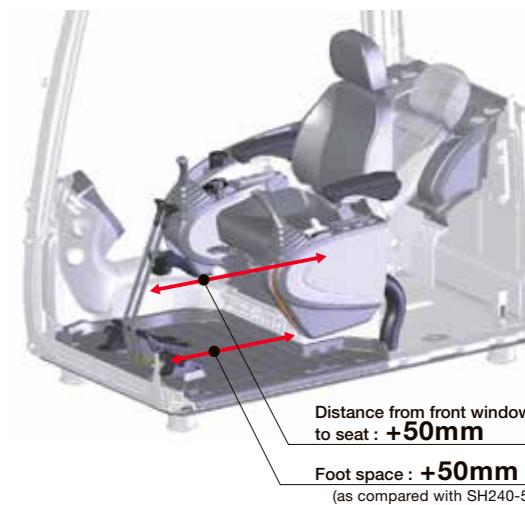

Sophisticated Reclining Seat

The seat reclining system allows the operator to lay the seat flat and to rest on site without having to remove the headrest. The suspension seat eliminates vibration and fatigue. Air suspension is also available as option.

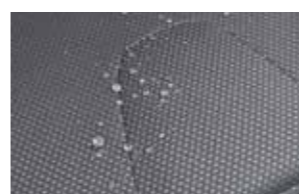

The highly water repellant seat covering is tough on dirt and water.



Air suspension (option)

Auxiliary Operation Pedal

The auxiliary operation pedal is lighter to depress and the pedal angle is adjustable.



Comfortable Equipment



Luggage space



Hot & cool box



Magazine rack

Automatic Air Conditioner

Fully automatic climate control is available through the eight vents, with an 8% stronger A/C unit, and a 24% improvement in airflow. (as compared with SH240-5)



Radio and Speaker with USB Port and MP3 Jack

In addition to the AM/FM radio and dual speaker system with improved sound quality, auxiliary audio port is provided standard for devices such as MP3 players.



Lever Switches

One-touch idle, horn, radio mute, or one-touch wiper buttons are installed on the operation levers in consideration of improved operability while working.



Radio mute switch (left lever)



One-touch wiper switch (right lever)



Safety and Operator Comfort

To support the operator in the field, the DASH 6 incorporates a 7" wide full-colour LCD monitor with numerous functions and universally designed switch panel. The cabin with enhanced operator comfort ensures a safe working environment.

Large High-Definition LCD Monitor

A new large high-definition full-colour LCD monitor has been introduced with better visibility and a switch panel which is easy to operate. Added functionality such as ECO gauge showing parameter of energy saving, display of operation status and warning messages, provides accurate information which improves work efficiency and safety.

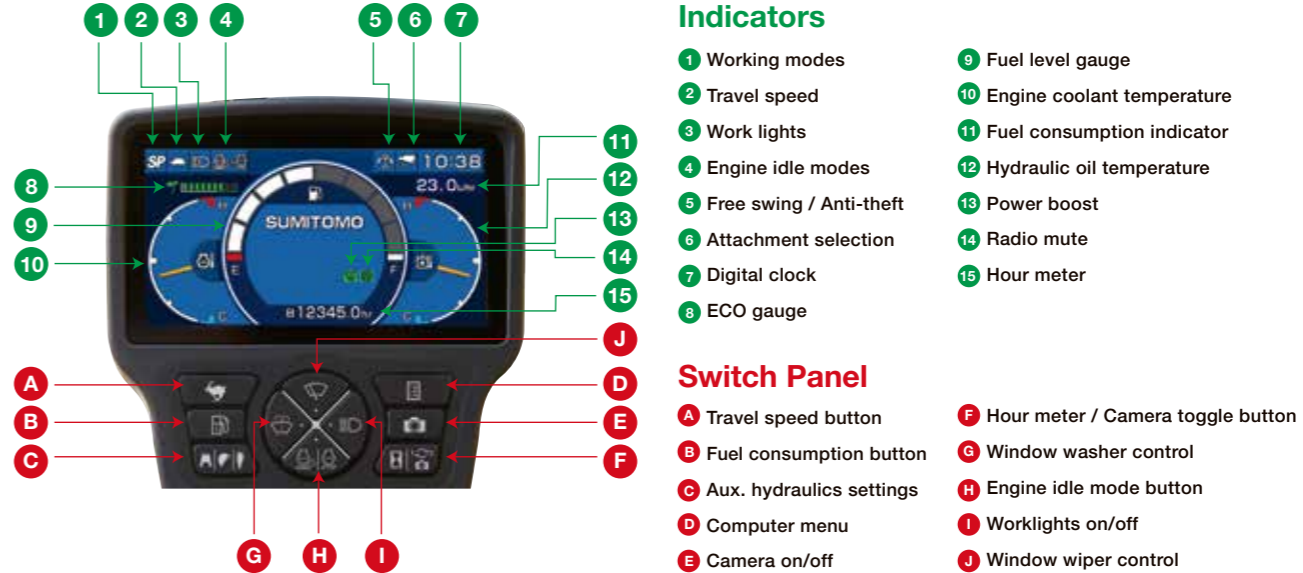

Rearview Camera (option)

With the rearview camera, the operator can view the image on the large LCD monitor. A side camera is available as option and up to two different images can be displayed on the monitor.



Rearview Mirror

The rearview mirrors reduce blind spots during operation. ISO compliant mirrors also available as option.



Specifications

SH250-6 Technical Data

Electronic-controlled engine of SPACE 5+ and SIH:S+ with New Hydraulic System Includes: three working modes (SP, H and A), one-touch/automatic idling system, automatic power-boost, speed assistance system, power-swing system.

Engine

SH250-6	
Model	ISUZU GH-4HK1X
Type	Water-cooled, 4-cycle diesel, 4-cylinder in line, high pressure common rail system (electric control), Turbocharger with air-cooled intercooler.
Rated output	132.1 kW (179.6 PS) at 2,000 min ⁻¹ (rpm)
Maximum torque	622 N·m at 1,800 min ⁻¹ (rpm)
Piston displacement	5.193 ltr
Bore and stroke	115 mm x 125 mm
Starting system	24 V electric motor starting
Alternator	24 V, 50 A
Fuel tank	410 ltr
Air filter	Double element

Hydraulic pumps

Two variable displacement axial piston pumps provide power for boom/arm/bucket, swing, and travel. One gear pump for pilot controls.

SH250-6	
Maximum oil flow	2 x 234 ltr/min
Pilot pump max. oil flow	20 ltr/min

Hydraulic motors

For travel: Two variable displacement axial piston motors.
For swing: One fixed displacement axial piston motor.

Working circuit pressure

Boom/arm/bucket 34.3 MPa (350 kgf/cm²)
Boom/arm/bucket 36.8 MPa (375 kgf/cm²) with auto power-up
Swing circuit 28.9 MPa (295 kgf/cm²)
Travel circuit 34.3 MPa (350 kgf/cm²)

Control valve

With boom/arm holding valve
One 4-spool valve for right track travel, bucket, boom and arm acceleration
One 5-spool valve for left track travel, auxiliary, swing, boom acceleration and arm

Oil filtration

Return filter 6 microns
Pilot filter 8 microns
Suction filter 105 microns

Hydraulic cylinders

Cylinder	Q'ty	Bore x Rod Diameter x Stroke
Boom	2	130 mm x 90 mm x 1,335 mm
Arm	1	145 mm x 105 mm x 1,660 mm
Bucket	1	130 mm x 90 mm x 1,070 mm

Double-acting, bolt-up-type cylinder tube-end; hardened steel bushings are installed in the cylinder tube and rods ends.

Cabin & controls

The cabin is mounted on four fluid mountings. Features include safety glass front, rear and side windows, adjustable upholstered suspension seat with headrest and armrest, cigarette lighter, pop-up skylight window, and intermittent wiper with washer.
The front window slides upward for storage and the lower front window is removable. Control levers are located in four positions tilting control consoles. Built-in type full-colour monitor display. Membrane switch on monitor display.

Swing

Planetary reduction is powered by an axial piston motor. The internal ring gear with has a grease cavity for pinion. The swing bearing is a single-row shear type ball bearing. Dual stage relief valves are used for smooth swing deceleration and stops. A mechanical disc swing brake is included.

SH250-6	
Swing speed	0~11.0 min ⁻¹ (rpm)
Tail swing radius	2,950 mm
Swing torque	74.9 kN·m (7,638 kgf·m)

Undercarriage

An X-style carbody is integrally welded for strength and durability. The grease cylinder track adjusters have shock absorbing springs. The undercarriage has lubricated rollers and idlers.

Type of shoe: sealed link shoe

Upper rollers -

Heat treated, mounted on steel bushings with leaded bronze casting, sealed for lifetime lubrication.

Lower rollers -

Heat treated, mounted on steel bushings with leaded bronze casting, sealed for lifetime lubrication.

Track adjustment -

Idler axles adjusted with grease cylinder integral with each side frame; adjustment yoke mechanism fitted with heavy duty recoil spring.

Number of rollers and shoes on each side

SH250-6	
Upper rollers	2
Lower rollers	9
Track shoes	51

Travel system

Two-speed independent hydrostatic system with compact axial motors for increased performance. Hydraulic motor powered output shaft coupled to a planetary reduction unit and track sprocket. All hydraulic components mounted within the width of side frame.
Travel speed can be selected by the switch panel on the monitor display. Hydraulically released disc parking brake is built into each motor.

SH250-6	
Travel speed	High 5.5 km/h Low 3.5 km/h
Drawbar pull	201 kN (20,496 kgf)

Lubricant & coolant capacity

SH250-6	
Hydraulic system	250 ltr
Hydraulic oil tank	147 ltr
Fuel tank	410 ltr
Cooling system	30.2 ltr
Final drive case (per side)	5.0 ltr
Swing drive case	9.7 ltr
Engine crank case	23.1 ltr

Auxiliary hydraulic system

SH250-6			
Auxiliary piping type (option)	For Breaker	For Double (breaker & crusher) acting	For D/A + Second option line
Arm type	STD	HD	HD
Bucket linkage type	HD	HD	HD
Auxiliary hydraulic pump flow	234 ltr/min	468 ltr/min	468+67 ltr/min

Bucket

Options and specifications may differ depending on countries and regions

Model		SH250-6					
Bucket capacity (ISO/SAE/PCSA heaped)		0.80 M3	1.00 M3	1.10 M3	1.20 M3	1.30 M3	
Bucket capacity (CECE heaped)		0.70 M3	0.85 M3	0.90 M3	1.00 M3	1.10 M3	
Bucket type		STD	STD	STD	Level-pin Reinforced level-pin	Reinforced level-pin	STD Level-pin Reinforced level-pin
Number of teeth		4	5	5	5	5	
Width unit: mm	With side cutter	1,086	1,276	1,360	1,470	1,560	
	Without side cutter	985	1,175	1,260	1,370	1,460	
Weight unit: kg		753	849	880 883 965	1,012	953 957 1,049	
Combination	2.50 m arm	○	○	○	○	●	
	3.00 m arm	○	○	●	○	○	
	3.52 m arm	○	●	○	○	○	

○ Suitable for materials with density up to 2,000 kg/m³ or less

○ Suitable for materials with density up to 1,600 kg/m³ or less

● Standard bucket (Suitable for materials with density up to 1,800 kg/m³ or less)

Weight & Ground Pressure

Model		SH250-6		
Shoe type	Shoe width	Overall width	Operating weight	Ground pressure
Triple grouser shoe	600 mm	3,190 mm	24,800 kg	49 kPa
	700 mm	3,290 mm	25,100 kg	43 kPa
	800 mm	3,390 mm	25,400 kg	38 kPa

Digging Force

Model		SH250-6		
Arm length		2.50 m	3.00 m	3.52 m
Bucket digging force (with auto power up)	ISO 6015	162 kN (174 kN)	162 kN (174 kN)	162 kN (174 kN)
	SAE: PCSA	145 kN (155 kN)	145 kN (155 kN)	145 kN (155 kN)
Arm digging force (with auto power up)	ISO 6015	141 kN (151 kN)	120 kN (129 kN)	107 kN (115 kN)
	SAE: PCSA	136 kN (146 kN)	116 kN (125 kN)	104 kN (112 kN)

Lifting Capacity

- Notes: 1. Ratings are based on ISO 10567
 2. Lifting capacity does not exceed 75% of tipping load with the machine on firm, level ground or 87% full hydraulic capacity.
 3. The load point is a hook (not standard equipment) located on the back of the bucket.
 4. *Indicates load limited by hydraulic capacity.
 5. 0 m = Ground.

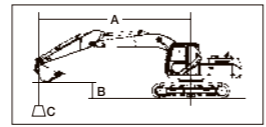

A: Radius of load
 B: Bucket hook height
 C: Lifting capacity



Unit: kg

SH250-6		SHOE : 600 (mm) G BUCKET : SAE/PCSA 1.1 (m ³)		ARM LENGTH : 3.00 (m) MAXIMUM REACH : 10.30 (m)		BOOM : 5.85 (m)		Radius of Load																		
Bucket Hook Height	Max. Radius	9 m		8 m		7 m		6 m		5 m		4 m		3 m		2 m		1 m		Min. Radius						
		(kg)	(m)	(kg)	(m)	(kg)	(m)	(kg)	(m)	(kg)	(m)	(kg)	(m)	(kg)	(m)	(kg)	(m)	(kg)	(m)	(kg)	(m)					
8 m	2400*	7.83	2400*	7.83			3100*	3100*													2850*	6.77	2850*	6.77		
7 m	2270*	8.57	2270*	8.57		3920*	3920*	4290*	4290*													4360*	6.64	4360*	6.64	
6 m	2210*	9.12	2210*	9.12	2790*	2790*	4660*	4030	5100*	5040*												5240*	6.53	5240*	6.53	
5 m	2190*	9.51	2190*	9.51	4040*	3150	5030*	3960	5500*	5040												5670*	6.09	5670*	6.09	
4 m	2200*	9.77	2200*	9.77	4660*	3090	5440*	3860	5900*	4890	6530*	6280*	7370*	7370*								4880*	3.99	4880*	3.99	
3 m	2260*	9.90	2260*	9.90	4600	3030	5650	3760	6540*	4730	7380*	6120	8690*	8160*	10930*	10930*	13340*	13340*				9610*	2.24	9610*	2.24	
2 m	2330*	9.92	2330*	9.92	4520	2960	5530	3650	6880	4570	8200*	5870	9970*	7850	12820*	12040*	12040*					5200*	2.50	5200*	2.50	
1 m	2450*	9.83	2450*	9.83	4450	2890	5420	3540	6750	4420	8670	5640	10990*	7490	10320*	10320*	10320*	8650*	8650*			3980*	2.33	3980*	2.33	
0 m	2630*	9.64	2530	9.64	4400	2840	5330	3460	6620	4290	8510	5460	11530	7230	14640*	10260	9210*	9210*	5320*	5320*		4060*	1.58	4060*	1.58	
-1 m	2870*	9.33	2660	9.33	4370	2820	5260	3400	6520	4200	8370	5340	11390	7080	15150*	10140	10750*	10750*	8070*	8070*	6520*	6520*	4360*	0.45	4360*	0.45
-2 m	3210*	8.90	2880	8.90			5260	3400	6490	4180	8320	5310	11350	7060	15130*	10160	12900*	12900*	9640*	9640*	9680*	9680*	6370*	0.23	6370*	0.23
-3 m	3730*	8.34	3220	8.34			5320	3480	6530	4230	8350	5340	11370	7100	14690*	10240	15810*	15810*	11920*	11920*	10320*	10320*	8420*	0.27	8420*	0.27
-4 m	4550*	7.61	3780	7.61			6620	4380	8430	5450	11010*	7220	13780*	10390	17940*	17310	15850*	15850*	12520*	12520*	11130*	0.59	11130*	0.59		
-5 m	6140*	6.68	4670	6.68			7760*	5670	9760*	7430	12210*	10600	15690*	15690*	19680*	19680*						15810*	1.26	15810*	1.26	
-6 m	5930*	5.44	5930*	5.44									7230*	7230*	9510*	9510*	12180*	12180*					13020*	2.75	13020*	2.75

SH250-6		SHOE : 600 (mm) G BUCKET : SAE/PCSA 1.3 (m ³)		ARM LENGTH : 2.50 (m) MAXIMUM REACH : 9.82 (m)		BOOM : 5.85 (m)		Radius of Load																		
Bucket Hook Height	Max. Radius	9 m		8 m		7 m		6 m		5 m		4 m		3 m		2 m		1 m		Min. Radius						
		(kg)	(m)	(kg)	(m)	(kg)	(m)	(kg)	(m)	(kg)	(m)	(kg)	(m)	(kg)	(m)	(kg)	(m)	(kg)	(m)	(kg)	(m)					
8 m	3490*	7.20	3490*	7.20			4340*	4340*														3880*	6.43	3880*	6.43	
7 m	3310*	8.02	3310*	8.02		3410*	3410*	5110*	5040														4370*	6.15	4370*	6.15
6 m	3210*	8.61	3210*	8.61		5120*	3890	5550*	5010														5760*	6.03	5760*	6.03
5 m	3180*	9.02	3000	9.02	3360*	3020	5400*	3840	5910*	4900	6190*	6190*											5570*	5.33	5570*	5.33
4 m	3200*	9.30	2790	9.30	4560	2990	5630	3750	6270*	4760	6970*	6200	8010*	8010*	8120*	8120*							5310*	2.38	5310*	2.38
3 m	3270*	9.44	2660	9.44	4500	2940	5540	3650	6820*	4610	7780*	5960	9310*	8020	10920*	10920*	12330*	12330*					7950*	2.96	7950*	2.96
2 m	3370*	9.46	2620	9.46	4440	2880	5430	3560	6800	4460	8540*	5730	10490*	7630	12700*	10850							7120*	3.16	7120*	3.16
1 m	3540*	9.36	2630	9.36	4390	2830	5340	3470	6650	4320	8580*	5520	11350*	7320	14090*	10350							6530*	3.03	6530*	3.03
0 m	3770*	9.16	2720	9.16	4350	2800	5260	3400	6540	4220	8410	5370	11430	7100	14830*	10100	8450*	8450*					5980*	2.50	5980*	2.50
-1 m	4120*	8.84	2880	8.84			5220	3360	6460	4150	8300	5270	11320	7020	15120*	10110	10680*	10680*	8600*	8600*			6310*	1.17	6310*	1.17
-2 m	4640*	8.38	3150	8.38			5270	3410	6470	4170	8300	5280	11330	7040	14880*	10180	13540*	13540*	10310*	10310*	9900*	9900*	6970*	0.74	6970*	0.74
-3 m	5400*	7.79	3580	7.79			6560	4260	8360	5360	11290*	7120	14210*	10290	17390*	16770	13110*	13110*	11470*	11470*	11470*	11470*	9910*	0.79	9910*	0.79
-4 m	6290*	7.01	4290	7.01			6350*	4300	8370	5530	10440*	7280	13000*	10480	16640*	16640*	17210*	17210*					14020*	1.16	14020*	1.16
-5 m	6260*	5.99	5580	5.99									8700*	7430	10980*	10520	13910*	13910*					18480*	2.00	18480*	2.00

SH250-6		SHOE : 600 (mm) G BUCKET : SAE/PCSA 1.0 (m ³)		ARM LENGTH : 3.52 (m) MAXIMUM REACH : 10.80 (m)		BOOM : 5.85 (m)		Radius of Load																			
Bucket Hook Height	Max. Radius	10 m		9 m		8 m		7 m		6 m		5 m		4 m		3 m		2 m		1 m		0 m		Min. Radius			
		(kg)	(m)	(kg)	(m)	(kg)	(m)	(kg)	(m)	(kg)	(m)	(kg)	(m)	(kg)	(m)	(kg)	(m)	(kg)	(m)	(kg)	(m)	(kg)	(m)	(kg)	(m)		
8 m	1910*	8.48	1910*	8.48			3110*	3110*	2560*	2560*														2570*	6.97	2570*	6.97
7 m	1810*	9.17	1810*	9.17		2410*	2410*	3790*	3790*															3790*	7.14	3790*	7.14
6 m	1760*	9.68	1760*	9.68		3450*	3240	4140*	4100															4710*	7.05	4710*	7.05
5 m	1730*	10.04	1730*	10.04	1940*	1940*	4020*	3200	4540*	4020	4990*	4950												5020*	6.67	5020*	6.67
4 m	1750*	10.28	1750*	10.28	2870*	2520	4520*	3140	5120*	3920	5420*	4980	5750*	5750*										5250*	5.57	5250*	5.57
3 m	1790*	10.41	1790*	10.41	3360*	2480	4630	3060	5550*	3800	6140*	4800	6870*	6220	7960*	7960*	9720*	9720*					6230*	1.84	6230*	1.84	
2 m	1840*	10.43	1840*	10.43	3600*	2430	4550	2980	5570	3680	6740*	4630	7740*	5970	9300*	8010	11950*	11340	15000*	15000*			4970*	2.15	4970*	2.15	
1 m	1940*	10.34	1940*	10.34	3550*	2380	4460	2900	5440	3560	6800	4460	8530*	5720	10450*	7610	13680*	10850	10590*	10590*	3580*	3580*	3320*	1.94	3320*	1.94	
0 m	2070*	10.16	2070*	10.16	2980*	2350	4390	2830	5340	3460	6640	4310	8560	5500	11280*	7300	14330*	10370	9650*	9650*	5410*	5410*	3420*	0.90	3310*	0.90	
-1 m	2260*	9.87	2260*	9.87			4340	2790	5250	3390	6520	4200	8390	5350	11420	7080	14940*	10120	10510*	10510*	7240*	7240*	5920*	4.760*	4760*	0	
-2 m	2510*	9.46	2510*	9.46			4340	2790	5220	3350	6450	4140	8290	5270	11310	7010	15160*	10080	12140*	12140*	8820*	8820*	8200*	7.130*	7130*	0	
-3 m	2890*	8.94	2840	8.94			5250	3390	6460	4160	8290	5280	11320	7030	14920*	10130	14430*	14430*	10760*	10760*	9170*	9170*	8660*	8660*	8660*	0	
-4 m	3450*	8.26	3250	8.26			5290	3480	6540	4240	8360	5350	11280*	7110	14290*	10250	17670*	17670*	13470*	13470*	11020*		9050*	0.02	9050*	0.02	
-5 m	4390*	7.40	3930	7.40			6560	4390	8350	5520	10440*	7270	13100*	10440	17080*	17060*	18280*	18280*	13420*	13420*			12090*	0.59	12090*	0.59	
-6 m	5810*	6.30	5150	6.30									6640*	5620	8720*	7420	11050*	10500	14270*	14270*	19730*	19730*		18780*	1.64	18780*	1.64

- Notes: 1. Ratings are based on ISO 10567
 2. Lifting capacity does not exceed 75% of tipping load with the machine on firm, level ground or 87% full hydraulic capacity.
 3. The load point is a hook (not standard equipment) located on the back of the bucket.
 4. *Indicates load limited by hydraulic capacity.
 5. 0 m = Ground.

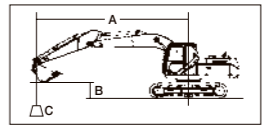

A: Radius of load
 B: Bucket hook height
 C: Lifting capacity

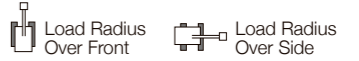

Unit: kg

SH250-6		SHOE : 700 (mm) G BUCKET : SAE/PCSA 1.1 (m ³)		ARM LENGTH : 3.00 (m) MAXIMUM REACH : 10.30 (m)		BOOM : 5.85 (m)		Radius of Load																			
Bucket Hook Height	Max. Radius	9 m		8 m		7 m		6 m		5 m		4 m		3 m		2 m		1 m		Min. Radius							
		(kg)	(m)	(kg)	(m)	(kg)	(m)	(kg)	(m)	(kg)	(m)	(kg)	(m)	(kg)	(m)	(kg)	(m)	(kg)	(m)	(kg)	(m)						
8 m	2400*	7.83	2400*	7.83																				2850*	6.77	2850*	6.77
7 m	2270*	8.57	2270*	8.57																							

Lifting Capacity

- Notes: 1. Ratings are based on ISO 10567
 2. Lifting capacity does not exceed 75% of tipping load with the machine on firm, level ground or 87% full hydraulic capacity.
 3. The load point is a hook (not standard equipment) located on the back of the bucket.
 4. *Indicates load limited by hydraulic capacity.
 5. 0 m = Ground.

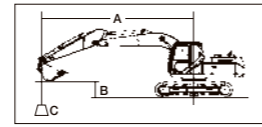

A: Radius of load
 B: Bucket hook height
 C: Lifting capacity



Unit: kg

SH250-6

SHOE : 800 (mm) G
 BUCKET : SAE/PCSA 1.1 (m³)
 ARM LENGTH : 3.00 (m)
 MAXIMUM REACH : 10.30 (m)
 BOOM : 5.85 (m)

Bucket Hook Height	Max. Radius		Radius of Load										Min. Radius															
			9 m		8 m		7 m		6 m		5 m				4 m		3 m		2 m		1 m							
	(kg)	(m)	(kg)	(m)	(kg)	(m)	(kg)	(m)	(kg)	(m)	(kg)	(m)	(kg)	(m)	(kg)	(m)	(kg)	(m)	(kg)	(m)								
8 m	2400*	7.83	2400*	7.83			3100*	3100*													2850*	6.77	2850*	6.77				
7 m	2270*	8.57	2270*	8.57			3920*	3920*	4290*	4290*											4360*	6.64	4360*	6.64				
6 m	2210*	9.12	2210*	9.12			2790*	2790*	4660*	4120	5100*	5100*									5240*	6.53	5240*	6.53				
5 m	2190*	9.51	2190*	9.51			4040*	3230	5030*	4050	5500*	5130									5670*	6.09	5670*	6.09				
4 m	2200*	9.77	2200*	9.77			4770*	3180	5440*	3960	5900*	5010	6530*	6390	7370*	7370*					4880*	3.99	4880*	3.99				
3 m	2260*	9.90	2260*	9.90			4720	3110	5770	3850	6540*	4840	7380*	6260	8690*	8300*	10930*	10930*	13340*	13340*		9610*	2.24	9610*	2.24			
2 m	2330*	9.92	2330*	9.92			4650	3040	5670	3740	7020*	4680	8200*	6010	9970*	8020	12820*	11460	12040*	12040*		5200*	2.50	5200*	2.50			
1 m	2450*	9.83	2450*	9.83			4680	2980	5560	3640	6930	4530	8850*	5780	10990*	7670	13910*	10870	8650*	8650*		3980*	2.33	3980*	2.33			
0 m	2630*	9.64	2610	9.64			4520	2930	5470	3560	6790	4410	8730	5600	11640*	7410	14640*	10500	9210*	9210*	5320*	5320*		4060*	1.58	4060*	1.58	
-1 m	2870*	9.33	2740	9.33			4500	2900	5410	3500	6690	4320	8590	5480	11680	7250	15150*	10380	10750*	10750*	8070*	8070*	6520*	6520*	4360*	0.45	4360*	0.45
-2 m	3210*	8.90	2970	8.90				5410	3500	6660	4290	8540	5440	11640	7230	15130*	10400	12900*	12900*	9640*	9640*	9680*	9680*	6370*	0.23	6370*	0.23	
-3 m	3730*	8.34	3310	8.34				5470*	3580	6700	4340	8570	5480	11600	7280	14690*	10480	15810*	15810*	11920*	11920*	10320*	10320*	8420*	0.27	8420*	0.27	
-4 m	4550*	7.61	3860	7.61					6780*	4490	8620*	5590	11010*	7390	13780*	10630	17940*	17600*	15850*	15850*	12520*	12520*	11130*	0.59	11130*	0.59		
-5 m	6140*	6.68	4790	6.68						7760*	5800	9760*	7610	12210*	10810	15690*	15690*	19680*	19680*			15810*	1.26	15810*	1.26			
-6 m	5930*	5.44	5930*	5.44											7230*	7230*	9510*	9510*	12180*	12180*			13020*	2.75	13020*	2.75		

SH250-6

SHOE : 800 (mm) G
 BUCKET : SAE/PCSA 1.3 (m³)
 ARM LENGTH : 2.50 (m)
 MAXIMUM REACH : 9.82 (m)
 BOOM : 5.85 (m)

Bucket Hook Height	Max. Radius		Radius of Load										Min. Radius															
			9 m		8 m		7 m		6 m		5 m				4 m		3 m		2 m		1 m							
	(kg)	(m)	(kg)	(m)	(kg)	(m)	(kg)	(m)	(kg)	(m)	(kg)	(m)	(kg)	(m)	(kg)	(m)	(kg)	(m)	(kg)	(m)								
8 m	3490*	7.20	3490*	7.20					4340*	4340*														3880*	6.43	3880*	6.43	
7 m	3310*	8.02	3310*	8.02					5110*	5110*														4370*	6.15	4370*	6.15	
6 m	3210*	8.61	3210*	8.61					5120*	3990	5550*	5120*												5760*	6.03	5760*	6.03	
5 m	3180*	9.02	3090	9.02					3360*	3110	5400*	3930	5910*	5010	6190*	6190*								5570*	5.33	5570*	5.33	
4 m	3200*	9.30	2870	9.30					4680	3070	5740	3850	6270*	4880	6970*	6330	8010*	8010*	8120*	8120*				5310*	2.38	5310*	2.38	
3 m	3270*	9.44	2740	9.44					4630	3020	5690	3750	6820*	4720	7780*	6100	9310*	8200	10920*	10920*	12330*	12330*		7950*	2.96	7950*	2.96	
2 m	3370*	9.46	2690	9.46					4570	2960	5580	3650	6980	4570	8540*	5870	10490*	7810	12700*	11090				7120*	3.16	7120*	3.16	
1 m	3540*	9.36	2710	9.36					4510	2910	5480	3560	6830	4440	8790	5660	14090*	10590						6530*	3.03	6530*	3.03	
0 m	3770*	9.16	2800	9.16					4480	2880	5410	3500	6710	4330	8620	5510	11700	7280	14830*	10340	8450*	8450*		5980*	2.50	5980*	2.50	
-1 m	4120*	8.84	2970	8.84					5370	3460	6640	4260	8520	5410	11610	7190	15120*	10360	10680*	10680*	8600*	8600*		6310*	1.17	6310*	1.17	
-2 m	4640*	8.38	3240	8.38					5420	3500	6640	4280	8520	5420	11610	7210	14880*	10420	13540*	13540*	10310*	10310*	9900*	9900*	6970*	0.74	6970*	0.74
-3 m	5400*	7.79	3680	7.79					6730	4380	8580	5490	11340*	7290	14210*	10530	17390*	17130	13110*	13110*	11470*	11470*	11470*	11470*	9910*	0.79	9910*	0.79
-4 m	6290*	7.01	4410	7.01					6350*	4420	8450*	5660	10440*	7450	13000*	10720	16640*	16640*	17210*	17210*				14020*	1.16	14020*	1.16	
-5 m	6260*	5.99	5720	5.99											8700*	7590	10980*	10720	13910*	13910*				18480*	2.00	18480*	2.00	

SH250-6

SHOE : 800 (mm) G
 BUCKET : SAE/PCSA 1.0 (m³)
 ARM LENGTH : 3.52 (m)
 MAXIMUM REACH : 10.80 (m)
 BOOM : 5.85 (m)

Bucket Hook Height	Max. Radius		Radius of Load										Min. Radius																			
			10 m		9 m		8 m		7 m		6 m				5 m		4 m		3 m		2 m		1 m		0 m							
	(kg)	(m)	(kg)	(m)	(kg)	(m)	(kg)	(m)	(kg)	(m)	(kg)	(m)	(kg)	(m)	(kg)	(m)	(kg)	(m)	(kg)	(m)	(kg)	(m)	(kg)	(m)								
8 m	1910*	8.48	1910*	8.48					3110*	3110*	2560*	2560*													2570*	6.97	2570*	6.97				
7 m	1810*	9.17	1810*	9.17					2410*	2410*	3790*	3790*													3790*	7.14	3790*	7.14				
6 m	1760*	9.68	1760*	9.68					3450*	3330	4140*	4140*													4710*	7.05	4710*	7.05				
5 m	1730*	10.04	1730*	10.04					1940*	1940*	4020*	3280	4540*	4120	4990*	4990*									5020*	6.67	5020*	6.67				
4 m	1750*	10.28	1750*	10.28					2670*	2600	4520*	3220	5120*	4020	5420*	5080	5750*	5750*							5250*	5.57	5250*	5.57				
3 m	1790*	10.41	1790*	10.41					3360*	2550	4760	3140	5550*	3900	6140*	4920	6870*	6340*	7960*	7960*	9720*	9720*		6230*	6230*	6920*	1.84	6920*	1.84			
2 m	1840*	10.43	1840*	10.43					3600*	2500	4670	3060	5720	3780	6740*	4740	7740*	6110	9300*	8190	11950*	11540*	15000*	15000*	4970*	2.15	4970*	2.15				
1 m	1940*	10.34	1940*	10.34					3550*	2460	4590	2980	5590	3660	6970	4570	8530*	5850	10450*	7790	13680*	11090	10590*	10590*	3580*	3580*	3320*	1.94	3320*	1.94		
0 m	2070*	10.16	2070*	10.16					2980*	2420	4520	2920	5480	3560	6820	4430	8780	5640	11280*	7480	14330*	10620	9650*	9650*	5410*	5410*	3420*	3420*	3310*	0.90	3310*	0.90
-1 m	2260*	9.87	2260*	9.87					4470	2870	5400	3490	6700	4320	8600	5490	11690	7270	14940*	10360	10510*	10510*	7240*	7240*	5920*	5920*	4760*	4760*	4760*	0	4760*	0
-2 m	2510*	9.46	2510*	9.46					4470	2870	5360	3450	6630	4250	8510	5410	11600	7190	15160*	10320	12140*	12140*	8820*	8820*	8200*	8200*	7130*	7130*	7130*	0	7130*	0
-3 m	2890*	8.94	2890*	8.94					5400	3490	6640	4270	8510	5420	11600	7200	14920*	10370	14430*	14430*	10760*	10760*	9170*	9170*	8660*	8660*	8660*	0	8660*	0		
-4 m	3450*																															

Working Range

		SH250-6		
Arm length		2.50 m	3.00 m	3.52 m
Boom length		5.85 m		
A	Max digging radius	9,820 mm	10,280 mm	10,790 mm
B	Max digging depth	6,400 mm	6,900 mm	7,420 mm
C	Max digging height	9,560 mm	9,760 mm	10,070 mm
D	Max dumping height	6,550 mm	6,760 mm	7,060 mm
E	Max vertical wall cut depth	6,210 mm	6,740 mm	7,270 mm
F	Min front swing radius	3,980 mm	3,950 mm	3,950 mm
G	Rear end swing radius	2,950 mm		

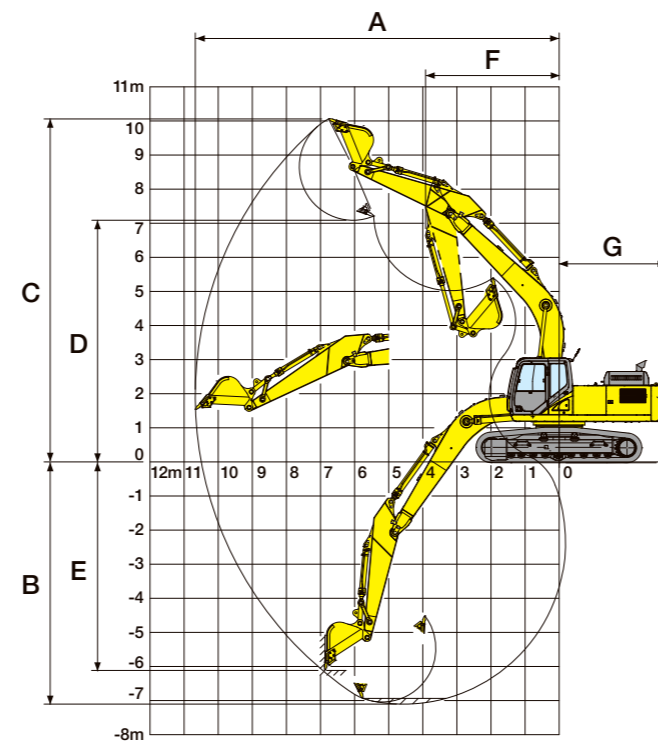

Principle Specifications

		SH250-6 STD Specifications
Base	Boom length	5.85 m
	Arm length	3.00 m
	Bucket capacity (ISO heaped)	1.10 M3
Engine	Std. operating weight	24,800 kg
	Make & model	ISUZU GH-4HK1X
Hydraulic System	Rated output	132.1 kW/2,000 min ⁻¹
	Displacement	5.193 ltr
	Main pump	2 variable displacement axial piston pumps with regulating system
	Max pressure	34.3 MPa
	/with auto power boost	36.8 MPa
Performance	Travel motor	Variable displacement axial piston motor
	Parking brake type	Mechanical disc brake
	Swing motor	Fixed displacement axial piston motor
	Travel speed	5.5/3.5 km/h
Others	Drawbar pull	201 kN
	Gradeability	70% <35°
	Ground pressure	49 kPa
	Swing speed	11.0 min ⁻¹
	Bucket digging force	162 kN
/with power boost	174 kN	
Arm digging force	120 kN (3.00 m arm)	
/with power boost	129 kN (3.00 m arm)	
Fuel tank	410 ltr	
Hydraulic fluid tank	147 ltr	

Standard Equipment

[Hydraulic system]

- SIH:S+ hydraulic system
- Operation mode (SP, H and A mode)
- Automatic 2-speed travel
- Automatic power boost
- Arm/boom/bucket reactivation circuit
- Automatic swing parking system
- High-performance return filter

[Cab/interior equipment]

- Top guard OPG level1 (in cab structure)
- Shock-less cab suspension by 4-point fluid mounts
- Built-in type full-colour monitor display
- Tilting console
- Open air introducing pressurised full-automatic air conditioner
- Defroster
- Hot & cool box
- KAB seat
- Seat suspension
- Armrest & headrest
- Windscreen wiper (with intermittent operation function)
- Cup holder
- AM/FM radio (with muting function and AUX port & USB port)
- Radio mute/ Windscreen wiper one-touch control on joystick
- Clock
- Magazine rack
- Accessory case
- Floor mat
- Ashtray & cigarette lighter
- Cab light (Auto-OFF function)
- Coat hook

[Safety equipment]

- Rearview mirror (left/right)
- Emergency escape tool
- Retracting seat belt
- Gate lock lever
- Travel alarm (with on and off switch)
- Anti-theft alarm system
- Engine room firewall
- Fan guard
- Engine emergency stop switch
- Engine neutral start

[Others]

- Auto/one-touch idling
- Auto idle shutdown system
- EMS
- Long-life hydraulic oil
- Two lights (main unit and left of boom)
- Fuel filter (with water separator)
- Fuel prefilter (with water separator)
- Double-element air cleaner
- Grease-enclosed track link
- Large tool box
- A set of tools

Accessories (option)

■ Cab-top lights



■ Rain deflector



■ Head guard (OPG level 2)



■ Polycarbonate roof top window with sunshade



■ Front guard (OPG level 1 or 2)



■ Front mesh guard (full/lower)



■ Precleaner



■ Air suspension (KAB seat)



- Refuel pump
- Hose burst check valve (HBCV) for boom/arm cylinders
- Straight travel pedal
- Side camera
- Rear view camera
- ISO compliant guardrail
- ISO compliant mirror
- ROPS Cabin

Dimensions

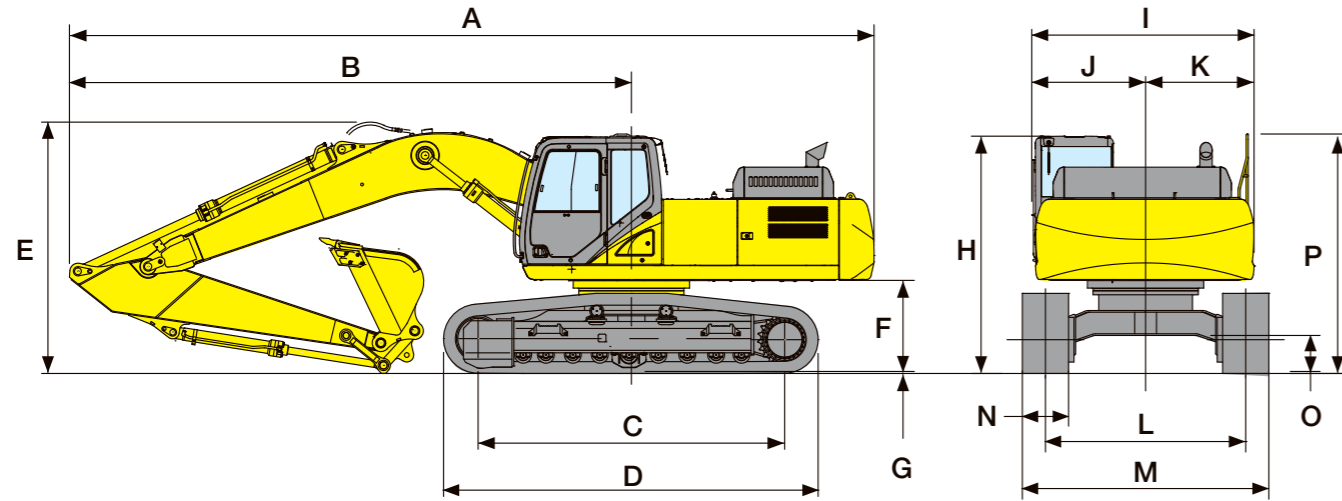

Model	SH250-6		
Arm length	2.50 m	3.00 m	3.52 m
A Overall length	9,980 mm	9,930 mm	9,910 mm
B Length from centre of machine (to arm top)	7,040 mm	6,990 mm	6,970 mm
C Centre to centre of wheels		3,840 mm	
D Overall track length		4,650 mm	
E Overall height (to top of boom)	3,310 mm	3,150 mm	3,310 mm
F Clearance height under upper structure		1,100 mm	
G Shoe lug height		26 mm	
H Overall height (to top of cab)		3,000 mm	
I Upper structure overall width		2,770 mm	
J Width from centre of machine (left side)		1,430 mm	
K Width from centre of machine (right side)		1,340 mm	
L Track gauge		2,590 mm	
M Overall width		3,190 mm	
N Std. shoe width		600 mm	
O Minimum ground clearance		440 mm	
P Overall height (to top of handrail)		3,020 mm	

MEMO