

MB-LS140

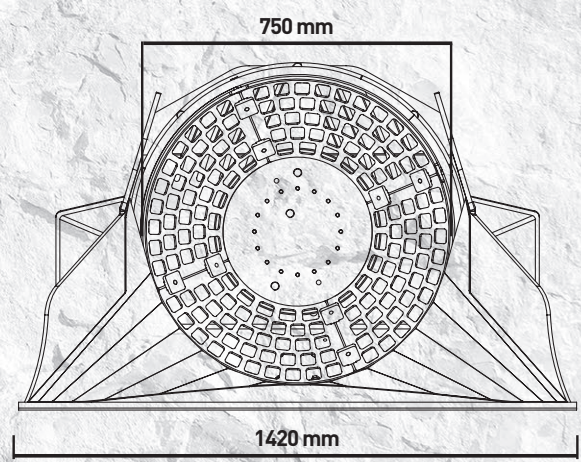

“Handy and efficient”

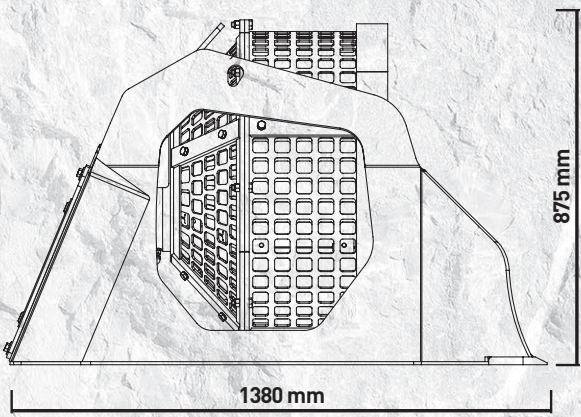
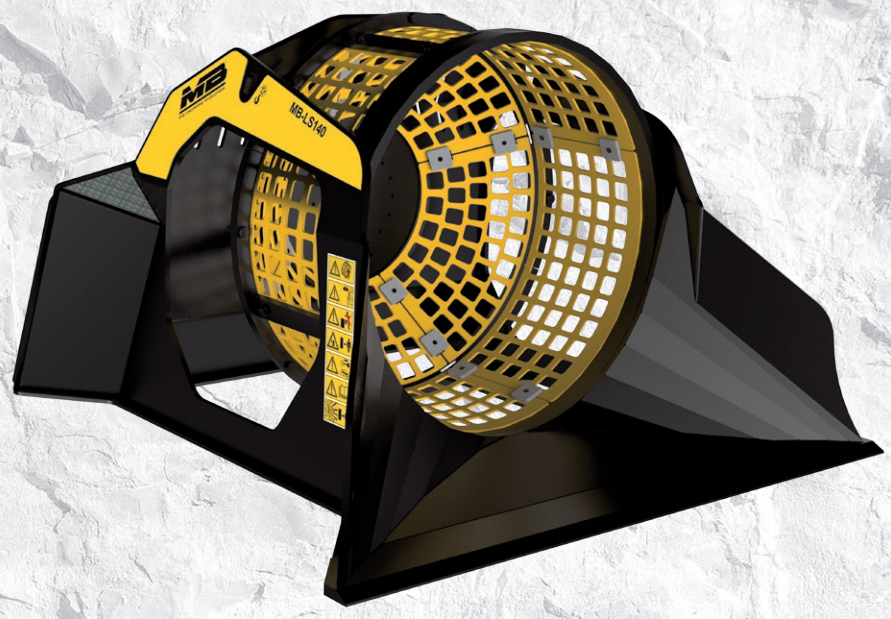
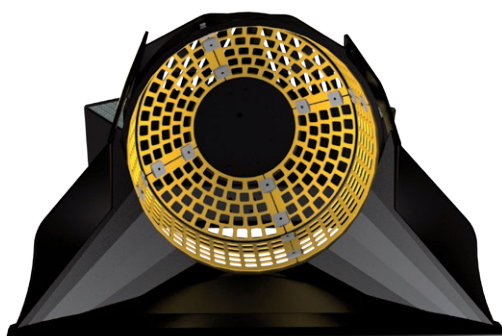

Ideal for the selection of natural material, in pre and post crushing, the screening bucket MB-LS140 allows to reduce up to 60% of the times of crushing and therefore allows to recover the material suitable for the type of processing desired and manage it in the best way.

Applicable to loader, skid steer and backhoe.



PRIMARY SELECTION:

- WASTE MATERIAL
- DEMOLITION MATERIAL
- EXCAVATION FILLING MATERIAL
- STONY GROUND RECLAIM
- PEBBLES IN STREAMS
- DEBRIS IN BEACHES
- NATURAL STONES CLEANING

SPECIFICATIONS

EQUIPMENT	LOAD CAPACITY	BASKET DEPTH	GRID DIAMETER	DIMENSIONS
SKID LOADER ≥ 2,6 Ton	0,50 m ³	550 mm	750 mm	1380 x 1420 H 875 mm
OIL FLOW	PRESSURE	COUNTER PRESSURE DRAIN	WEIGHT	SPEED/MIN.
50 l/min.	150 bar	-	0,45 Ton	25 / 30 min/max

ACCESSORIES

RECOMMENDED SPARE PARTS KIT	FIXED COUPLER	QUICK FEMALE COUPLER	HOUR METER	
MBS100015	-	-	804MBBV01	
				24 MONTHS WARRANTY
				WA241402

The data provided above is not binding, as the manufacturer reserves itself the right to make improvements to its products at any time and with no advance notice. References to excavator weights are approximate and many may be subject to changes. Consider a 20% tolerance.