

MB-L200 S2

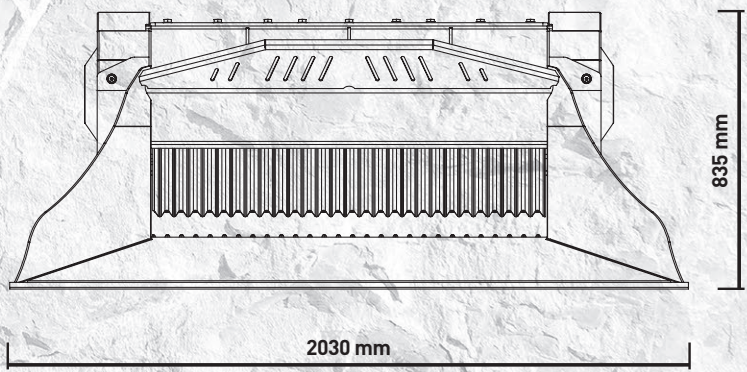

“The crusher bucket **changes shape**”

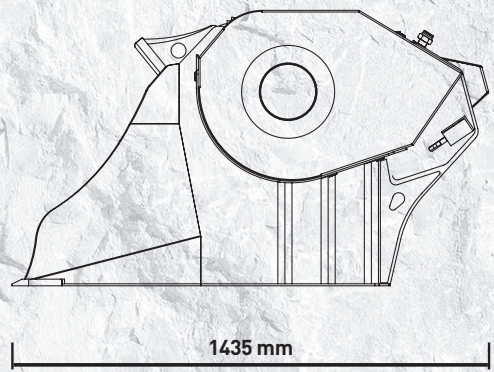
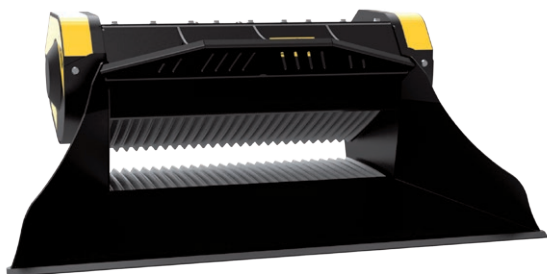

Made with the same materials and technology as the full line of MB crusher buckets, the MB-L200 S2 was designed on the basis of specific work requirements for skid loaders and backhoes.

MB-L200 S2 crusher is suitable for skid loaders starting from 6 Ton and backhoes between 7 and 10 Ton.

Changing the shape of the crusher does not affect the high performance and resistance of MB products.



AREAS OF APPLICATION

- DEMOLITION
- RECYCLING
- ROAD WORKS
- EXCAVATION

SPECIFICATIONS

EQUIPMENT	LOAD CAPACITY	OPENING DIMENSIONS	OUTPUT SETTING	DIMENSIONS
SKID LOADER ≥ 6 Ton BACKHOE LOADER / LOADER ≥ 7 ≤ 10 Ton	0,45 m ³	L 1150 H 260 mm	≥ 15 ≤ 60 mm	1435 x 2030 H 835 mm
OIL FLOW	PRESSURE	COUNTER PRESSURE	WEIGHT	MAXIMUM PRODUCTION
120 l/min.	200 bar	20 bar	1,50 Ton	22 m ³ /h

ACCESSORIES

RECOMMENDED SPARE PARTS KIT	FIX COUPLER	QUICK FEMALE COUPLER	IRON SEPARATOR	HOUR METER
MBL160020	-	-	-	804MBNF01
			DUST SUPPRESSION KIT	24 MONTHS WARRANTY
			KNMB00L-KNMB00S-KNMB00M	WA242000

The data provided above is not binding, as the manufacturer reserves itself the right to make improvements to its products at any time and with no advance notice. References to excavator weights are approximate and many may be subject to changes. Consider a 20% tolerance.